

Layout For Continuous Sandwich Panel Line Using Pentane

Dry Side

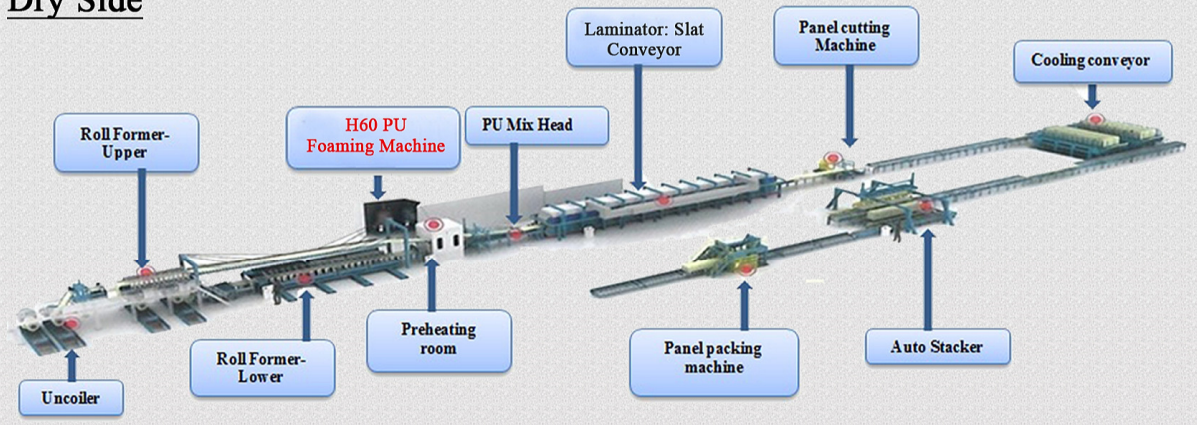

- DRY SIDE**
Comprised of :-
- 1) Uncoiler
 - 2) Upper / lower Roll forming machine (roofing / wall / cold room panel)
 - 3) Pre-heat system
 - 4) Double belt conveyor
 - 5) Panel cutting device
 - 6) Panel auto stacking machine
 - 7) Panel packaging machine (option)
 - 8) Cooling conveyor (option)

Wet Side

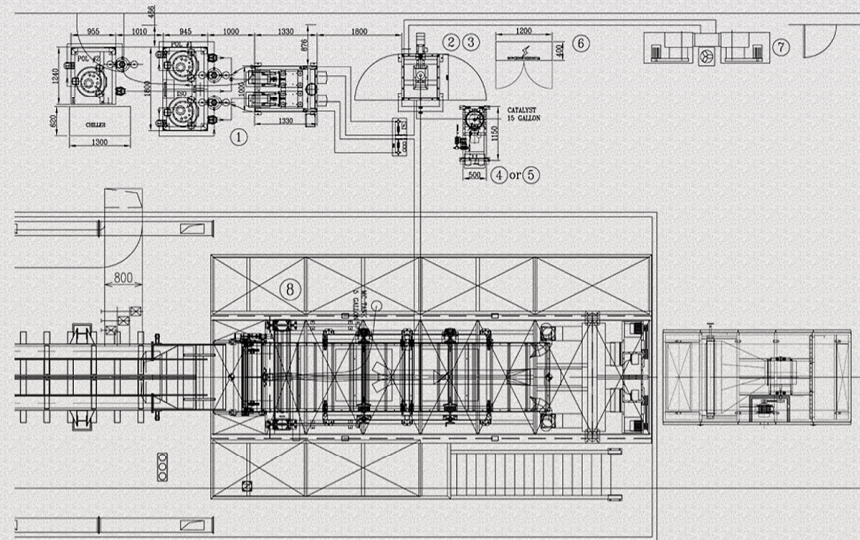

- WET SIDE**
Comprised of :-
- 1) GMA H60 High pressure foaming machine
 - 2) GMA CX-4C High pressure mixing station (Based on GMA patented technology)
 - 3) High pressure pentane metering system
 - 4) High pressure catalyst / Additive metering system (PUR)
 - 5) High pressure catalyst / Additive metering system (PIR)
 - 6) Automatic gas alarm detecting system for Pentane system
 - 7) Ventilation & exhaust system
 - 8) X-Y-Z Mix head carrier system

Applications

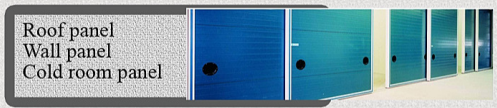

Rim Polymers Industries Pte Ltd
 209 Henderson Road, #03-08 Henderson Industrial Park, Singapore 159551
 Tel: (65) 6278 3288 Fax: (65) 6271 0426
 Email: rim_polymers@cehgroup.com Web: www.rimpolymers.com
 www.facebook.com/rimpolymers @RimPolymers
 Regional Offices: China • Indonesia • India • Malaysia • South Korea • Thailand • Vietnam •



Pentane Technology for Continuous Sandwich Panel Plant

a great way to foam ..

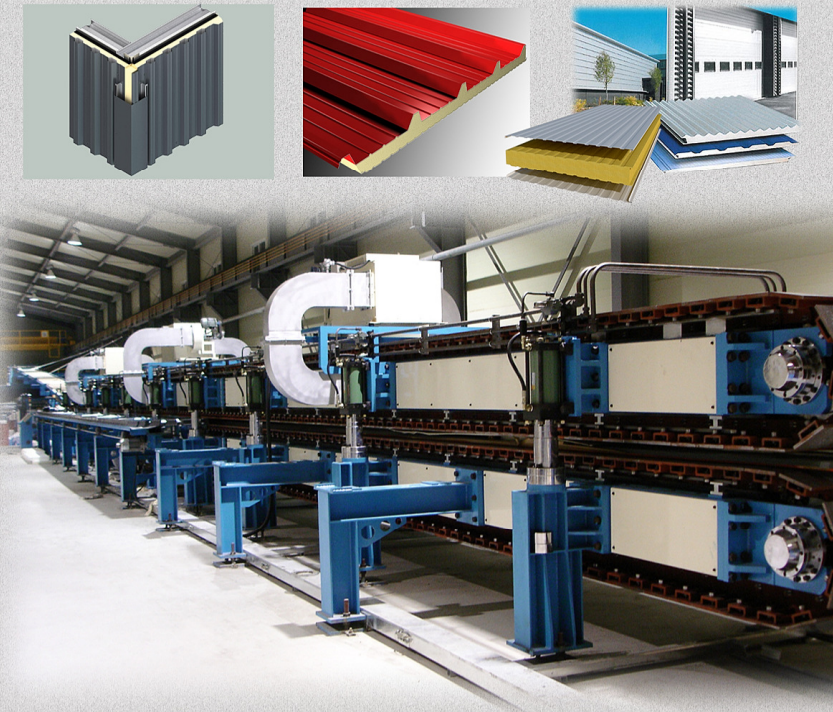

Turn-Key Solution For Continuous Sandwich Panel Line Using Pentane Technology

Commonly used for Building Wall, Roof, and Cold storage applications. The equipments used include Decoiler, Film Coverer, Top and Bottom Roll Forming, Preheating Device, High Pressure Injection Machine, Mix Head Carrier, Double Laminator, Auto Cutting Device, Flipping Device, Lifting & Stacking System and others such as Cooling System, Packaging Machine as options.

The Continuous PU Sandwich Panel system can be used for both steel or flexible facing. A typical continuous line Double laminator comes in 16m, 24m, 30m depending on buyer's needs and requirements. High Pressure Foaming machine of 2 - 8 components and the dry plant continuous line can be supplied as a whole complete turnkey system.

If Pentane is used as the blowing agent, the whole plant is dedicated to use explosion proof, intrinsically safe apparatus and interface with Pentane storage system, ventilation exhaust system and automatic gas sensors alarm system.

Pentane Storage/ Premix System

There are 4 systems in a complete 4C high pressure premix system. They are:-

- 1) 1 no. Blowing agent (Pentane) Metering group
- 2) 2 no. Catalyst Metering group
- 3) 1 no. Static Mixer with Intermediate mixing chamber for 4 components (Polyol/Catalyst 1/ Catalyst 2/ Pentane blowing agent)

Cyclopentane Tank
Pressurize Tank System
- 100/270/500/1000
- 35,000 m³ Tank for Pentane



Raw Polyol Tank
Pressurize Jacketed Tank System
- 270/ 500/1000/ 2000 litres



High Pressure Foaming Machine for PUR/PIR



Model: GMA H60

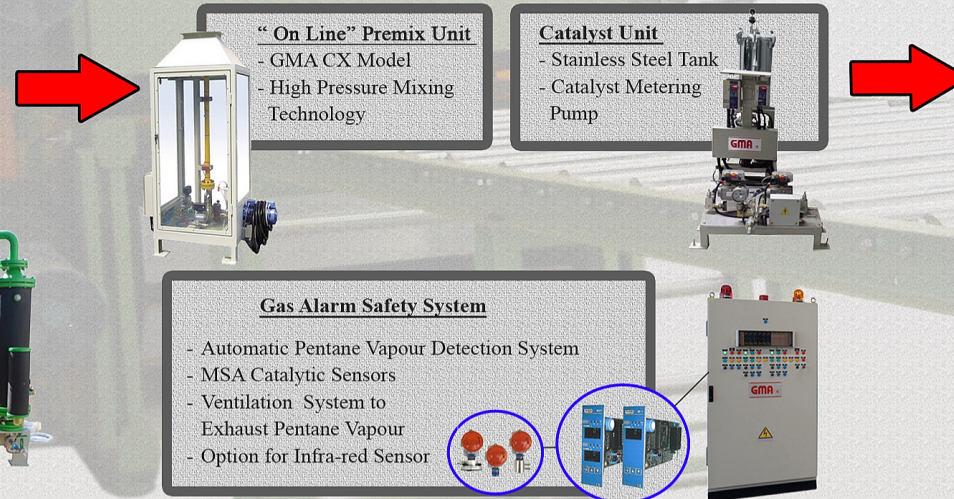

Continuous Sandwich Panel Plant

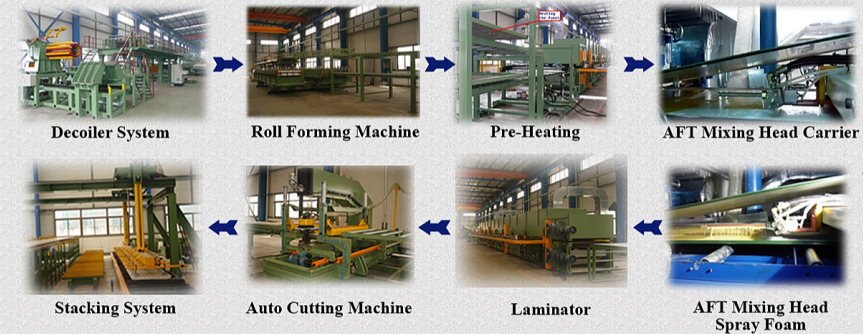

Technical Specification

- Line Speed (meter/min): 2~6; 2~12 (actual speed depends on chemical system)
- Production Line External Dimension (m): Length: 103~150
Width: 7~18
Height: 4~6
- Steel Sheet Thickness (mm): 0.4~0.7
- PU Panel Thickness (mm): 20~200
- Double Belt Laminator Length (m): 16/24/30
- Approximate Power Consumption (KVA): 230~350

